

Framed by

INFINIUM



**ALU**k

# A MODERN MASTERPIECE

Like the finest pieces of art great architecture inspires. It evokes discussion and stirs emotions. At times it demands attention. Other times reflection. And at its most powerful, it beautifully unifies indoor and outdoor worlds.

The Infinium aluminium sliding door embodies these principles with picture-perfect precision, turning every view into an ever-changing work of art.





# BEAUTIFULLY CONSIDERED

Infinium brings together indoor and outdoor living spaces in exquisite harmony. Free-flowing spaces are created thanks to stunningly slim sightlines that bathe every surface with natural light. Uninterrupted panoramic landscapes provide complete escapism, without need of escape. While seamlessly integrated floor-to-ceiling glazing reflects the clarity of thought behind every inspired design decision.





# EXCEPTIONAL DESIGN, WITHOUT EXCEPTION

Fully concealed aluminium outer frame and sash. Flush thresholds. Elegantly simple operation. Infinium's considered design impresses from every angle. However, its most remarkable design feature barely catches the eye. The impossibly thin 21mm sightlines create the illusion of large endless spaces. The effect is charming, yet practical.

Minimalist, yet undeniably magical.

PERFORMANCE

INFINIUM

# HIDDEN BEAUTY

Great architecture isn't simply built on aesthetic appeal. It's judged equally on the way it makes you feel. The way it protects, calms and reacts to your mood. Infinium was designed with comfort firmly in mind. For example, double thermal breaks improve insulation and bring added warmth into the home. While also keeping unwanted noises out.





# INSPIRED DECISION- MAKING

Freedom. That most sought-after design feature.

It's what turns a property into a passion project.

Where every decision brings you ever closer to your dream home. Infinium offers choice in abundance.

Double and triple track options are available.

Up to six sashes are achievable. While a floating 90° corner post effortlessly ties every living space.



VERSATILE

# FLAWLESS EXECUTION

Attention to detail. It's so often what separates good from great.

It's why bespoke aluminium rollers have been designed to ensure the heaviest Infinium door requires only the lightest touch to open.

For added ease, and further distinction, an automated motorised system is available. Handles are cleverly concealed, yet always near at hand. And while the outside world is welcomed into the home, uninvited guests are kept safely locked out.

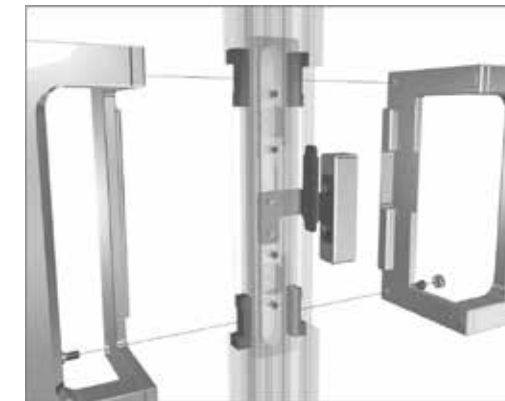

DETAIL

T: 01633 81 04 40

E: [info@aluk.co.uk](mailto:info@aluk.co.uk)

W: [aluk.co.uk](http://aluk.co.uk)

Registered Office:

AluK (GB), Limited Imperial Park, Celtic Way, Newport NP10 8BE

Registered Number:

02881320

[aluk.co.uk](http://aluk.co.uk)

**ALUK**<sup>®</sup>

## TECHNICAL SPECIFICATIONS

The new AluK sliding door system, Infinium allows for wide panoramic views with natural daylight and offers greater comfort. Its high levels of thermal and acoustic insulation combined with its wide range of configurations will satisfy any architectural requirements. Options include one or more opening panels with large width and height dimensions up to 3000mm (W) and 3500mm (H), and a floating corner post which allows for a larger opening space.

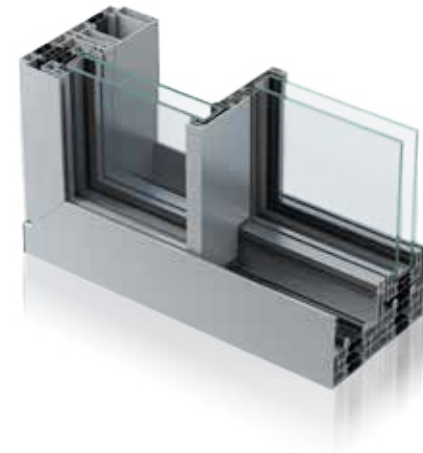

## DESIGN FEATURES

- Inline sliding door
- Fully concealed outer-frame
- 21mm central interlock
- One or more opening panels with large width dimensions up to 3000mm (W) and height dimensions up to 3500mm
- Holds up to 400 kg panel weight

## OPTIONS

- Available in double or triple track
- Glazing options of 38mm – 52mm
- Floating corner post option for larger opening space
- Single or dual colour options, also available in anodised or powder coating finishes
- Available in a range of configurations
- Double or triple glazing solutions available on the same outer-frame

## HARDWARE

- A bespoke central lock fully integrated into the interlock
- Lateral locking handle with concealed mechanism
- Motorised lock and sliding mechanism

## SPECIFICATIONS

<b>Performance and accreditation</b>	
Uw-Value (Double Glazing)	1.3 W/m²K
Uw-Value (Triple Glazing)	< 1.0 W/m²K
Air Tightness	Class 4 (600 Pa)
Water Tightness	Class 8A (450 Pa)
Wind Load	Class C3 (1200 Pa, up to 160 km/h)
<b>Size limits</b>	
Max Sash Weight	400kg
Max Sash Dimension	3000mm (w)   3500mm (h)
<b>System features</b>	
Dual colour option	✓
Multi-point locking	✓
Glazing options	38mm   52mm

## CAD CROSS SECTIONS

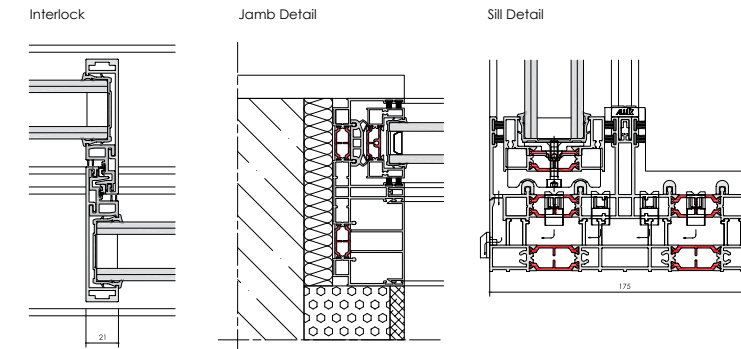

## CONFIGURATIONS

The diagrams showed here illustrate some of the configurations achievable with AluK's Infinium system.

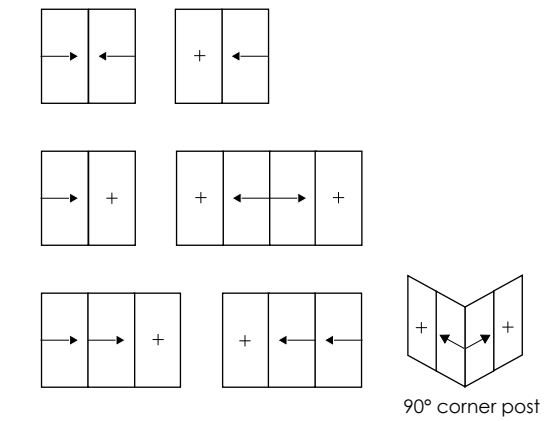

## KEY

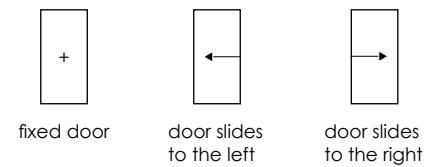

## THERMAL MAPPING

